

City University of New York (CUNY)

CUNY Academic Works

Student Theses

Baruch College

1-1-1991

Cranial foramina and relationships of dipodoid rodents

Michael Andrew Dempsey
Baruch College

[How does access to this work benefit you? Let us know!](#)

More information about this work at: https://academicworks.cuny.edu/bb_etds/14

Discover additional works at: <https://academicworks.cuny.edu>

This work is made publicly available by the City University of New York (CUNY).
Contact: AcademicWorks@cuny.edu

Cranial Foramina and Relationships of Dipodoid Rodents

by Michael Andrew Dempsey ©

Submitted to the Committee on Undergraduate Honors of Baruch College of The City University of New York in partial fulfillment of the requirements for the degree of Bachelor of Arts in Biology with Honors

November 14, 1991

TABLE OF CONTENTS

ABSTRACT

INTRODUCTION

Why Rodents Merit Study

Characteristics of the Rodentia

Value of Cranial Foramina in the Study of Relationships

The Dipodoidea

Purpose of this Study

METHODS

Data Collection and Analysis

Specimens Examined

RESULTS

Cranial Foramina

Other Cranial Features

DISCUSSION

CONCLUSIONS

ACKNOWLEDGEMENTS

LITERATURE CITED

APPENDICES

A. Sample Data Capture Page

B. Character State Polarization

C. Data Matrix

ABSTRACT

Cranial foramina of dipodoid rodents (jerboas, jumping mice, and birch mice) were examined and analyzed with PAUP (Phylogenetic Analysis Using Parsimony) in order to test hypotheses of interrelationship and evaluate published classifications of the superfamily. Ninety-three specimens of thirteen genera (specimens of Euchoreutes were unavailable) were examined with a dissecting microscope, and data for forty-one

foramina and related features in each were recorded. These were compared with data from the extinct Eocene genus *Paramys* and the muroid genus *Cricetulus* as outgroup taxa. Data on foramina were encoded and tabulated for computer analysis. Two equally parsimonious cladograms or family trees were produced and combined in a strict consensus tree. Data were resampled in a "bootstrap" analysis, and the most commonly recurrent relationships in 100 such tests were shown in a majority rule consensus tree.

Both kinds of analysis support division of the Dipodoidea into two families, Dipodidae (jerboas) and Zapodidae (jumping mice). *Sicista*, the birch mouse, is within the zapodid clade. The position of *Eozapus* is equivocal; it may be the sister taxon of the entire Dipodoidea or of the Dipodidae. *Zapus* plus *Napaeozapus* and *Dipus* plus *Jaculus* form two related pairs of taxa within their respective families. Other phylogenetic relationships are not strongly supported.

INTRODUCTION

Why Rodents Merit Study

The Rodentia is the largest mammalian order with over 1700 species, and it accounts for half of all living mammals. Rodents are found on all continents and in markedly different environments from the arctic to the desert. Each environment has exerted selective pressures that have resulted in great morphological diversity and specialization among rodents (Wood, 1974). These mammals, which are usually herbivorous and occasionally omnivorous, may be aquatic (beavers), terrestrial (mice and rats), arboreal (squirrels), subterranean (gophers) or volant (flying squirrels). Their ability to adapt quickly and successfully has ensured their survival and proliferation. For these reasons the study of rodents is merited.

Characteristics of the Rodentia

Rodents are characterized by the presence of a single pair of ever-growing incisors in both the upper and lower jaws. Tullberg (1899) broadly categorized rodents into two distinct groups which he called sciurognathous and hystricognathous on the basis of jaw morphology. When viewed ventrally, the angle of the jaw in sciurognathous rodents arises in the plane of the incisor, whereas in hystricognathous rodents the angle arises lateral to the plane of the incisor. The Sciuridae, squirrels, are clear examples of sciurognathous morphology, the Hystricidae, Old World porcupines, of the hystricognathous condition.

The Rodentia have also been divided into four suborders based on the arrangement of lateral and medial parts of the masseter muscle, which is used in gnawing and chewing ([Fig. 1](#)). The lateral and medial parts of the masseter arise on the lateral and medial faces of the zygomatic arch or cheekbone respectively and insert on the lower jaw. These suborders are the Protrogomorpha (early rodents, such as the extinct *Paramys*),

Sciuromorpha (squirrels and beavers), Hystricomorpha (porcupines and guinea pigs), and Myomorpha (mice, rats, jerboas). Protrogomorphous rodents are considered to be primitive because the masseter origin is limited to the ventral surface of the zygoma, the bony arch on the side of the skull. In sciuromorphic rodents the anterior part of the lateral masseter extends anterodorsally from the zygoma onto the side of the snout. Hystricomorphous rodents have a portion of the medial masseter that extends anterodorsally from the orbit, through an enlarged infraorbital foramen in the zygomatic arch, onto the side of the snout. The infraorbital foramen transmits only nerves and blood vessels from the orbit to the rostrum in primitive rodents. Enlargement of the foramen for passage of muscle is an advanced condition, and the mode of its evolutionary development is disputed. It is traditionally assumed that the foramen simply enlarged to accommodate the muscle.

The myomorphous rodents combine sciuromorphic and hystricomorphous muscle arrangements. Protrogomorphs, sciuromorphs and myomorphs are sciurognathous, while most hystricomorphs are hystricognathous. Below the subordinal level, the classification of rodents becomes very difficult because of parallel evolution, convergence, divergence, and an inadequate fossil record.

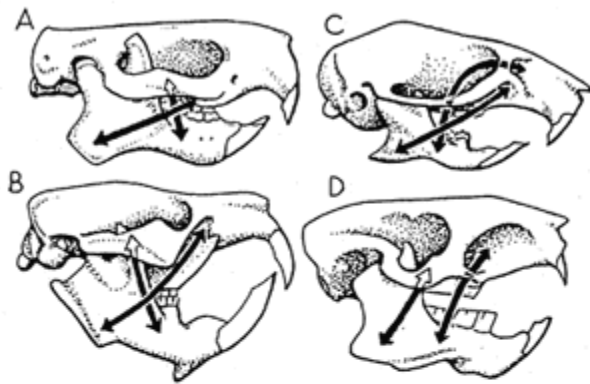

Figure 1. Position of lateral and medial divisions of masseter muscle in rodents (superficial layer omitted). A, a protrogomorph; the entire masseter originates mainly from the lower edge of the zygomatic arch. B, an advanced sciuromorph; the lateral division of the masseter originates from the side of the rostrum, the medial division from the medial side of the zygomatic arch. C, a myomorph; the lateral division of the masseter is similar, but the medial division has pushed up through the orbit and passes through the infraorbital foramen onto the rostrum. D, a hystricomorph; the lateral division of the masseter arises on the zygomatic arch, but the medial division passes through the infraorbital foramen onto the rostrum (after Romer, 1966, fig. 437).

Value of Cranial Foramina in the Study of Relationships

Paleontologists and mammalogists (e.g., Wahleff, 1974, 1991) have successfully established relationships among rodents with study and analysis of cranial foramina. Foramina are the holes that penetrate bones and allow passage of nerves, arteries, and veins through them. The skull is especially perforated with foramina since it houses the brain, and nerves and vessels must pass through bone to reach the eye socket and sensory hairs on the side of the snout. The positions of cranial foramina relative to one another, to the dentition, and to the sutures where bone meets bone vary; much of this variation is consistent within related species and can be used to provide new data for analysis of relationships. The cranial foramina are especially important since they belong to systems that are mostly independent of the masseter musculature and dental characteristics on which hypotheses of interrelationship are traditionally based.

The Dipodoidea

The superfamily Dipodoidea consists of the jumping mice (Zapodidae), birch mice (*Sicista*) and jerboas (Dipodidae); their distribution is given in [Figure 2](#). The infraorbital foramen is of intermediate size between the myomorphs and hystricomorphs. In all of these rodents this foramen transmits nerves and blood vessels from the orbit onto the side of the snout where they reach sensory whiskers, and a deep part of the masseter muscle that is used in chewing. The dipodoids are considered to be myomorph rodents and the sister taxon to the Muroidea (rats and mice), although they lack the sciuriform component of the masseter muscle. Emry (1981), described a fossil rodent that is related to living dipodoids; it possesses two infraorbital foramina. Emry proposed that the medial masseter originally penetrated the maxillary jugal suture to form a completely separate foramen that subsequently united with the primitive infraorbital foramen.

Jerboas (family Dipodidae) are leaping rodents of the Old World that live in arid areas, such as deserts, and have enlarged auditory chambers called bullae. The middle three metatarsals of their hind feet are fused together into a single cannon bone; this is a specialization for leaping. Jumping mice (family Zapodidae, including *Sicista*, the birch mouse), which live in North America and the Palearctic (chiefly eastern Asia), have small auditory bullae; in addition all of the digits are separate, and their hind limbs are only slightly adapted for saltatory locomotion.



Figure 2. Geographic distribution of dipodoid rodents (from Klingener, 1984, fig. 63).

Below the superfamily level, several different classifications of the Dipodoidea have been proposed:

Ellerman, 1940:

Family Dipodidae

Subfamily Sicistinae

Subfamily Zapodinae

Subfamily Cardiocraniinae

Subfamily Euchoreutinae

Subfamily Dipodinae

Simpson, 1945:

Family Zapodidae

Subfamily Sicistinae

Subfamily Zapodinae

Family Dipodidae

Subfamily Dipodinae

Subfamily Cardiocraniinae

Subfamily Euchoreutinae

Klingener, 1984:

Family Dipodidae

Subfamily Sicistinae
Subfamily Zapodinae
Subfamily Cardiocraniinae
Subfamily Euchoreutinae
Subfamily Allactaginae
Subfamily Dipodinae

McKenna, personal communication (manuscript in preparation):

Family Dipodidae

Subfamily Zapodinae

Tribe Sicisfinae
Tribe Zapodinae

Subfamily Dipodinae

Tribe Allactagini
Tribe Dipodini

Subfamily Cardiocraniinae

Subfamily Euchoreutinae

Recently, Stein (1990) suggested, on the basis of comparative limb myology, that *Sicista* be placed in a family of its own, the Sicistidae.

Purpose of this study

The purpose of this study is to examine cranial foramina and related structures in members of the superfamily Dipodoidea and to use these new data to resolve problems of their interrelationships. The diagram of relationships, a phylogenetic tree in the form of a cladogram, will provide a means of evaluating the various classifications that have been proposed for the superfamily. This study is founded upon soft tissue anatomy examined and recorded by Sheets (1989) in an Honors Thesis.

METHODS

Data Collection and Analysis

The research on dipodoid rodent skulls was performed in the Department of Mammalogy at the American Museum of Natural History. Ninety three specimens of 13 genera were selected; different species and a variety of localities were sampled in order to identify the range of variation within each genus. In some cases, e.g., *Pygeretmus*, the sample was restricted by the small number of specimens available and by the geographic limitation of a single collecting locality. The skulls, which are quite small and range from about 1.5 to 3.5 mm in length, were examined with a Nikon dissecting microscope with fiber optic light source. Measurements were taken using a Helios Dial Caliper accurate to 0.05 mm.

Each of the 41 foramina and related features was treated as a separate cranial character and assigned a notebook page for data collection (example shown in Appendix A); variant forms of a foramen, such as its size and position, are its character states. All foramina in every skull of the sample were examined and their different character states recorded. Examination of a particular foramen in each of the 93 specimens required approximately two days of observations. Some specimens were incompletely cleaned, and muscle and connective tissue adhering to the bone had to be softened with warm water and carefully removed. The existing variety of character states of each foramen became apparent for each genus.

Paramys was selected as an outgroup, or hypothesized ancestral taxon, because its skull is primitive with respect to most other extinct and living rodents. *Cricetulus* was chosen as the second outgroup since it is a representative muroid rodent; the Muroidea (rats, mice, and hamsters) is considered to be the sister taxon of the Dipodoidea. Character states were then evaluated and numerically encoded for analysis with a computer program called PAUP, Phylogenetic Analysis Using Parsimony (Swofford, 1989), and a Mackintosh IIx Computer (40 megabytes).

The state of each foramen in the extinct Eocene rodent *Paramys* was considered to be primitive and rated as state 0. Data on cranial foramina in *Paramys* were taken from Wahlert (1974) and a manuscript in preparation (Wahlert, Korth, and McKenna, personal communication). Divergences from this primitive state observed in the sample of *Cricetulus* and dipodoids were assigned whole, positive numbers according to the number of character states observed and the degree of divergence from the primitive condition (Appendix B, Character State Polarization; Appendix C, Data Matrix).

The PAUP program analyzes such encoded data to test possible arrangements of the taxa in cladograms (phylogenetic or family trees) and to select that tree which is the most parsimonious or requires the smallest number of steps. A step is the transformation of a character from one state to another, such as 0 to 1. In this analysis the character states, although numbered, were not polarized; the program thus allows transformations to skip steps, such as a change from 0 to 3. This removes assumptions about evolutionary progress that could seriously bias the outcome. A consensus tree summarizes the points of certainty and uncertainty in the analysis. This was further examined by "bootstrap" analysis, a statistical technique that employs resampling from the data set and shows how well each node in the consensus tree is supported. One hundred new data matrices are randomly generated by selecting any combination of a few characters. New

clades, groups of taxa sharing a common ancestor, are assembled based on these matrices, and the frequency of specific groupings of taxa into clades are recorded. The groupings that occurred most frequently are summarized in a cladogram called the majority rule consensus tree.

This thesis was written according to the Style Manual of the American Museum of Natural History (Jones, 1988). Comparable studies are published in the journals of the museum.

Specimens Examined

All recent specimens are from the collection of the Department of Mammalogy, American Museum of Natural History, and they bear the acronym AMNH. The generic and specific names are in accord with Honacki, Kinman, and Koepl (1982). Ninety-three specimens of 13 genera were examined; no specimens of *Euchoreutes* were available. M and F indicate the sex of the individual specimen. Locality data is taken from the catalogue of the Department of Mammalogy.

Alacmgulus pumilio. 85331 M, 85332 M, 85333 M, Telekul, Kazakhstan; 98133 F, Touchilovka, Russian S. S. R.; 176266 M, SW Ust-Urt Plateau, Kazakhstan.

Allactaga bullata. 58777 M, W of Sair Usu, Mongolia; 256507 F, Trans-Altai Gobi, Mongolia. *Allactaga elater*. 256977 M, 256978 F, Alma-Ata Oblast, Kazakhstan; *Allactaga major*. 176268 F, Kharkin Village, Kazakhstan. *Allactaga natalinae*. 256509 F, Trans-Altai Gobi, Mongolia. *Allactaga sibirica*. 58641 M, 58691 M, Tuerin, Mongolia; 84328 ?, Tsagan Nor, Mongolia. *Allactaga svertzovi*. 176269 F, Trsara-Baba, Turkmen S. S. R.; 206589 F, Turkmen S. S. R.

Cardiocranius paradoxus. 84154 F, Shabarakh Usu, Mongolia.

Dipus sagitta. 4329 M, 7003 F, Central Park Zoo, N. Y.; 58519 M, Sair Usu, Mongolia; 58607 M, 58623 F, 84120 M, Tsagan Nor, Mongolia; 58843 F, Erhlien, Mongolia; 84140 M, 84148 F, Shabarakh Usu, Mongolia; 176265 M, Sarabel Village, Kazakhstan.

Jaculus blanfordi. 212115 M, Chaqui Division, Pakistan. *Jaculus jaculus*. 203226 F, 203227 F, Matrub, Egypt; 38910 M, Sadi Akba, Algeria. *Jaculus lichtensteini*. 174329 F, Kzyl Orda region, Kazakhstan. *Jaculus jaculus* or *Jaculus orientalis*. 2363 ?, Central Park Zoo; 80005 ?, 80006 ?, 80007 ?, New York Zoological Society, N. Y.

Paradipus ctenodactylus. 174332 ?, Bokhara, Uzbek S. S. R.

Pygeretmus shitkovi. 174330 F, 176264 F, Bur-Baital, Kazakhstan.

Salpingotus thomasi. 244428 M, 244430 F, 244433 F, Chaga Division, Baluchistan, Pakistan; 244429 ?, 244431 ?, 244432 F, Pakistan.

Stylodipus telum. 58546 M, 58548 F, 58551 F, Uskuk, Mongolia; 58617 F, 58624 M, Tsagan Nor, Mongolia; 58638 F, 58639 M, Loh, Mongolia; 84133 M, Shabarakh Usu, Mongolia; 174328 M, 176263 ?, Bur-Baital, Kazakhstan.

Sicista betulina. 206585 M, Deryabka, Russian S. F. S. R.; 206586 M, Mushenko, Yaroslavl Province, Russian S. F. S. R.; 178814 M, Mazharka, Krasnoyarsk Territory, Russian S. F. S. R. *Sicista concolor*. 37837 F, Sind Valley, Kashmir. *Sicista napaea*. 206587 M, Altai Province, Russian S. F. S. R. *Sicista subtilis*. 178829 M, Dmitrievka, Krasnoyarsk Territory, Russian S. F. S. R.; 206588 F, Soverovo, Chkalov Province, Russian S. F. S. R.

Eozapus setchuanus. 84264 M, Archuen, Kansu, China; 113580 M, Minya Konka, China.

Napaeozapus insignis. 64208 M, Mt. Albert, Quebec; 67789 F, Berlin, New York; 74718 F, Cascapedia River, Quebec; 97482 M, Mt. Washington, New Hampshire; 98948 F, Ausable River, New York; 143238 M, Mt. Washington, Massachusetts; 144484 M, Elk Lake, New York; 147363 F, 147365 M, Profile Lake, New Hampshire; 166179 F, Chittenden, Vermont; 180247 F, Near Conn. Lakes Customs Station, Canada.

Zapus hudsonius. 8177 F, Tobique Point, New Brunswick; 67763 F, Berlin, New York; 127815 M, Wood Buffalo Park, Slave River, Northwest Territory. *Zapus princeps*. 4145 F, Florida, Colorado; 9817 F, Sherman, Nebraska; 33624 M, Ironside, Oregon; 120666 F, 3 mi S Montana line, Fremont Co., Idaho; 138964 M, 1/2 mi S of Mineral King, Tulare Co., California; 144217 M, 30 mi S Bliss Creek Meadows, Wyoming. *Zapus trinotatus*. 38311 M, Tillamook, Oregon.

Cricetulus barabensis. 57902 F, Loh, Mongolia. *Cricetulus evermanni*. 57848 M, Tsagan Nor, Mongolia. *Cricetulus griseus*. 57930 F, Chili Shan Hae Kwan, China. *Cricetulus longicaudatus*. 56312 F, Lao Tsa Teu, China; 57724 F, Artsa Bogdo, Mongolia. *Cricetulus migratorius*. 176254 F, 20 km from Kara-Kala, Turkmen S. S. R.; 88829 M, Astarabad, Iran. *Cricetulus triton*. 33094 F, north China; 56724 F, Yenping Mts., Fukien Province, China.

RESULTS

Cranial Foramina

[Figure 3](#), the skull of the dipodid genus *Jaculus orientalis*, illustrates most of the foramina described. A zapidid skull, *Zapus hudsonius*, is presented in [Figure 4](#) for comparison. P indicates premolar and M, molar, in the following text.

Interpremaxillary

When present, the interpremaxillary foramen is situated in the median premaxillary-maxillary suture immediately posterior to the incisors. All of the dipodoids lack the interpremaxillary foramen. Three of the ten *Cricetulus* specimens examined (AMNH 56724, AMNH 57902, and AMNH 56312) possessed this character in its usual place. It transmits a branch of the palatine artery.

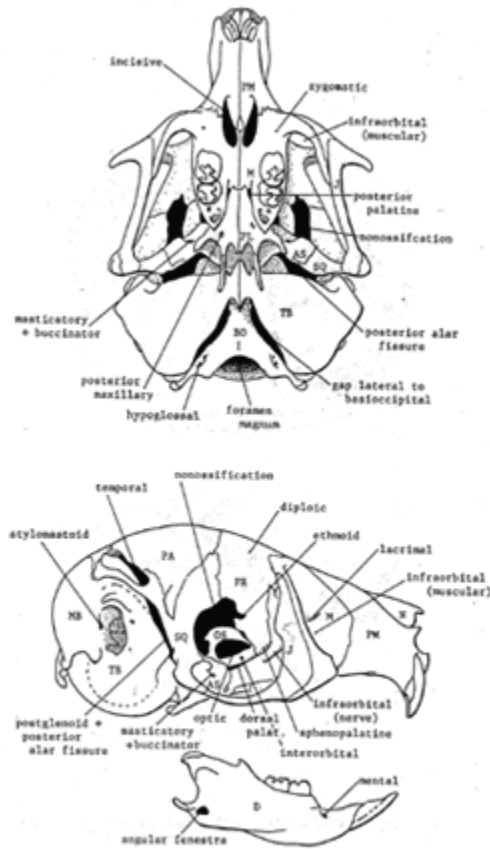

Figure 3. *Jaculus orientalis* (AMNH 80007), ventral and lateral views of skull (after Sheets, 1989, figs. 15 and 17).

Abbreviations of bone names: AS, alisphenoid; BO, basioccipital; D, dentary; FR, frontal; J, jugal; M, maxilla; MB, mastoid bulla; N, nasal; OS, orbitosphenoid; PA, parietal; PL, palatine; PM, premaxilla; SQ, squamosal; TS, tympanic bulla.

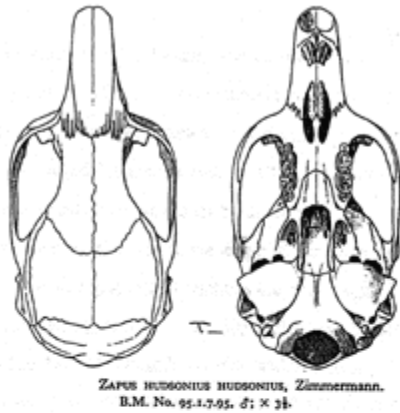

Figure 4. Skull of *Zapus hudsonius* (from Ellerman, 1940, figs. 147 and 148).

Incisive

The incisive foramina flank the diastema and are always intersected by the premaxillary-maxillary suture. The suture may intersect the foramen at the anterior, medial or posterior part of the incisive foramen. In *Cricetulus* the foramen is intersected by the suture towards its anterior end. In all the dipodoids incisive foramina were intersected medially or anteriorly by the suture.

There is some variety with respect to the length of this foramen. *Allactaga* has an average length of 7.0 mm, *Dipus* and *Pygeretmus* 6.0 mm, *Zapus*, *Napaeozapus*, *Alactagulus*, *Paradipus*, *Stylodipus*, *Jaculus*, and *Cricetulus* have lengths of 5.0 mm, *Sicista* and *Cardiocranius* 4.0 mm, *Eozapus* 3.0 mm, and *Salpingotus* 2.0 mm.

The ratio of length of the incisive foramina to diastemal length ranges from .53 to .88. *Cricetulus* has a ratio of .63, *Zapus*. 88, *Sicista*. 87, *Salpingotus*. 85, *Napaeozapus* .76, *Pygeretmus*, .72, *Eozapus*, .72, *Cardiocranius*, .69, *Dipus* .66, *Alactagulus*. 65, *Allactaga*. 65, *Paradipus*. 62, *Stylodipus*,. 62, and *Jaculus* .53.

The position of the posterior margin of the foramen relative to the dentition shows some variance. In dipodoids with a premolar (P4), *Zapus*, *Sicista*, *Eozapus*, *Cardiocranius*, *Stylodipus*, *Salpingotus*, *Dipus*, and *Allactaga*, it is always situated medial to the junction of the fourth premolar and the first molar. In genera lacking a premolar, *Cricetulus*, *Jaculus*, *Napaeozapus*, *Alactagulus*, and *Paradipus*, the incisive foramina are either anteromedial or medial to the anterior part of M1. This is in the same relative position as in the other group of rodents.

Palatine

There are two different character states pertaining to this foramen. Only in a single specimen of *Cricetulus* (AMNH 57848) is the foramen entirely within the palatine bone. In all of the dipodoids and the other specimens of *Cricetulus*, the foramen is situated in the maxillary-palatine suture.

The palatine foramen is in approximately the same position throughout the genera. The anterior border is medial to the anterior portion of the second molar, and the posterior border is medial to the posterior portion of the second molar. However, there are exceptions to this pattern. In specimens of *Alactagulus* (AMNH 98133, AMNH 85333, AMNH 176266, and AMNH 85332) the anterior border of the foramen is medial to the posterior region of the first molar and extends to the medial region of the second molar. One *Eozapus* specimen (AMNH 84264) is atypical with regard to the relative position of the foramen. It begins medial to the posterior portion of M2 and extends to the anterior portion of M3. Some dipodoid specimens have a pair of foramina posteromedial to the posterior palatine: *Jaculus*, AMNH 174329, AMNH 212115; *Allactaga*, AMNH 206589, AMNH 176268; *Dipus*, AMNH 176265; *Cricetulus*, AMNH 57848.

Posterior maxillary

In *Cricetulus* the posterior maxillary foramen is absent. In all of the dipodoid genera, except *Salpingotus*, the posterior maxillary foramen is situated in the maxillary pterygoid suture posterior to M3. The foramen may be either partially or completely enclosed. There is side to side variation in nine specimens (AMNH 4329, AMNH 176265, AMNH 70003, AMNH 174332, AMNH 176266, AMNH 67789, AMNH 174329, AMNH 80007, AMNH 203227). In *Napaeozapus* (AMNH 189247) there is a large pit immediately posterior to the third molar, and the posterior maxillary foramen may be part of this. In *Zapus* and three *Napaeozapus* (AMNH 74718, AMNH 147363, and AMNH 147365) the posterior maxillary is in the maxillary-ptyergoid suture and is more medially situated than in other specimens. In *Salpingotus* the posterior maxillary foramen is entirely within the pterygoid bone posteromedial to M3.

Infraorbital

The infraorbital foramen opens anteriorly on the side of the snout in the maxilla and is the anterior opening of the infraorbital canal. It transmits the infraorbital nerve, artery and vein. In the dipodoids there is a gradation towards subdivision into two distinct foramina. Only the outgroup taxon *Cricetulus* possesses a single foramen with no division.

The first step in the subdivision of the foramen is seen as a groove in the ventral part of the infraorbital foramen. The groove is the first step in the development of a second smaller foramen. *Salpingotus*, *Alactagulus* (AMNH 176266, AMNH 85331), *Eozapus*, *Paradipus*, *Dipus* (AMNH 58607 only), *Allactaga* (AMNH 256977), and *Sicista* all have this feature.

The second stage in the subdivision of the infraorbital is characterized by the presence of a flange of the maxilla that arises from the anterior part of the orbital floor and the ventral floor of the infraorbital canal; the flange leans medially and the dorsal edge may or may not touch the wall of the rostrum. All of *Zapus* and *Allactaga* (with the exception of AMNH 256977) possess this feature.

The third stage of separation is characterized by the presence of two distinct foramina. The larger foramen is posterolateral to the second which is much smaller and channel like. All members of *Jaculus*, *Dipus*, *Pygeretmus*, *Napaeozapus*, and *Stylodipus* have this feature as well as do two specimens of *Alactagulus* (AMNH 98133 and AMNH 85333).

Zygomatic

The zygomatic foramen, seen in ventral view, is situated in the maxilla anterior or anterolateral to P4 and posterior to the premaxillary-maxillary suture. In those specimens lacking a premolar the foramen is anterolateral to M1. *Cricetulus* specimens lack this character as do *Sicista*, *Zapus*, *Eozapus*, and *Napaeozapus*. All the remaining dipodoids have the foramen in the position described above. In addition, one *Jaculus* specimen (AMNH 203227) has two foramina on its left side, the first of which is anteromedial to the second. The function of this foramen is unknown.

Nasolacrimal

The nasolacrimal foramen is situated in the medial wall of the infraorbital canal posterolateral to the back of the incisor alveolus. All of the dipodoids and *Cricetulus* have this foramen, and no variation is seen.

Sphenopalatine

The sphenopalatine foramen is situated at the front end of the orbital process of the palatine bone. In *Cricetulus* the foramen is dorsomedial to M2, and its margins are formed by the maxillary, palatine, and frontal bones. There is significant variation among dipodoids with respect to this character.

In most *Zapus* and *Napaeozapus* the sphenopalatine is subdivided into two foramina by a strip of maxillary bone. The first foramen is anterolateral to the second and is completely enclosed in the maxillary bone. The second foramen is more dorsally situated; its posterior margin is intersected by the maxillary-frontal suture and the palatine bone is excluded. In two specimens of *Zapus* (AMNH 120666 and AMNH 4145) the foramen is entirely within the maxilla. In one *Napaeozapus* (AMNH 74718) the foramen is divided on one side only and is situated dorsomedial to the junction of M1 and M2. In *Eozapus* a

large sphenopalatine is situated dorsomedial to M2. The posterior margin of the foramen is formed by the maxillary and palatine bones and the frontal bone is excluded. In most specimens of the remaining dipodoid genera (*Dipus*, *Stylodipus*, *Alactagulus*, *Cardiocranius*, *Eozapus*, *Allactaga*, *Sicista*, and *Jaculus*) the sphenopalatine foramen is continuous with a large fenestra in the orbital wall; the anteroventral edge of the fenestra is the anterior margin of the foramen. A thin bony process from the palatine forms a posterior margin in one specimen each of *Jaculus* (AMNH 80005) and *Dipus* (AMNH 176265).

The anterior margin of the sphenopalatine foramen is dorsal to M2 in *Dipus*, *Eozapus*, and *Sicista*. It is above the junction of M1 and M2 in *Cricetulus Zapus*, *Stylodipus*, *Alactagulus*, *Cardiocranius*, *Allactaga*, *Pygeretmus*, *Jaculus*, and *Paradipus*.

Ethmoid

In all dipodoid genera examined this foramen is situated in the orbital lamina of the frontal bone posterior to the maxillary-frontal suture. Some specimens have a channel extending posteroventrally from the foramen to the area of nonossification of the frontal bone. All the *Zapus* specimens and some *Napaeozapus*, *Dipus*, *Paradipus*, *Pygeretmus*, and *Stylodipus* have this feature. *Cricetulus* has the foramen but not the channel.

In other specimens, which have the nonossification, a notch in the orbital lamina of the frontal bone indicates the position of the ethmoid foramen. This type of foramen is seen in *Jaculus*, *Dipus*, *Stylodipus*, *Alactagulus*, *Allactaga*, *Napaeozapus*, *Sicista*, and *Salpingotus*. In both *Cricetulus* and the dipodoids the location of the ethmoid foramen relative to the molars shows remarkable consistency. It is always situated dorsomedial to the molars and is found between the anterior portion of the second molar and the third molar. It is never located outside this range. Slight variations in position are observed within every dipodoid genus, except *Salpingotus*. All *Cricetulus* specimens have the ethmoid foramen dorsomedial to the anterior portion of the second molar.

Diploic

The diploic foramen (Miller, 1964) is situated in the orbital lamina of the frontal bone anterior to the squamosal-frontal suture and just ventral to the dorsal surface of the cranium. It transmits the diploic vein transversely into the cranial roof. In all *Cricetulus* specimens examined, except AMNH 144217, the foramen is present. In two *Cricetulus* (AMNH 33094 and AMNH 57848) the diploic foramen is present on the left side only. *Zapus*, *Napaeozapus* (except AMNH 147363), *Sicista*, and *Eozapus* also have this character in the same position as described above. All the remaining dipodoid rodents, *Salpingotus*, *Allactaga*, *Alactagulus*, *Jaculus*, *Stylodipus*, *Dipus*, *Paradipus*, *Pygeretmus*, *Cardiocranius*, and one *Napaeozapus* (AMNH 147363), lack the diploic foramen.

Optic

The optic foramen is situated in the orbitosphenoid bone and is either partially or completely enclosed by it. In all specimens the foramen is either dorsomedial to the

junction of M2 and M3 or both dorsomedial and posterior to M3. In *Cricetulus* the diameter of the optic foramen is consistently within the range of 1.0 mm to 1.2 mm. The zapodids, *Napaeozapus* and *Zapus*, also have diameters of 1.0 mm. Only in *Sicista* and *Cardiocranius* is the diameter less than 1.0 mm. The remaining dipodoids all have diameters larger than 1.0 mm for the optic foramen. The largest values, ranging from 2.1 mm to 2.9 mm, are in *Jaculus* and *Dipus*. In *Cricetulus* and all of the dipodoids, except *Dipus* and *Jaculus*, the posterior portion of the orbitosphenoid is fused with the alisphenoid. In the two genera excepted the orbitosphenoid is completely separated from the alisphenoid by the anterior alar fissure.

Interoptic

When present, the interoptic foramen is located in the orbitosphenoid bone anteroventral or ventral to the optic foramen. *Cricetulus* lacks the foramen. In *Jaculus* (AMNH 80007), *Cardiocranius*, *Salpingotus*, *Paradipus*, and some *Dipus* the interoptic is ventral relative to the optic foramen. *Allactaga* has an interoptic foramen situated in the orbitosphenoid anteroventral to the optic foramen. Two *Zapus* specimens (AMNH 138964 and AMNH 127815) also have the interoptic foramen, but it is anterior relative to the optic foramen. The foramen is absent in *Sicista*, *Jaculus* (except AMNH 80007), *Pygeretmus*, *Stylodipus*, *Alactagulus*, *Eozapus*, *Zapus* (except AMNH 138964 and AMNH 1278150), and some *Napaeozapus*.

Dorsal Palatine

In *Cricetulus*, the dorsal palatine foramen is situated in the palatine bone dorsomedial to M3. The palatine canal arises in the orbit, continues ventrally, and emerges in the posterior palatine foramen. There were two variations on this theme. In the first, seen in *Jaculus* (except AMNH 203226), *Pygeretmus*, *Stylodipus*, *Alactagulus*, *Cardiocranius*, *Eozapus*, *Zapus*, *Napaeozapus*, *Sicista*, *Salpingotus* and some *Dipus*, the dorsal palatine is continuous with a large area of nonossification between the orbitosphenoid and maxillary bones of the orbit. Hence the dorsal palatine foramen has no clearly defined boundaries.

In the second variation a piece of palatine bone extends anterodorsally to meet the maxilla. The dorsal palatine is contained within this ridge of bone just anterior to a second foramen whose function is unknown. All *Paradipus*, one *Jaculus* (AMNH 203226), and some *Dipus* (AMNH 58623, AMNH 176265, and AMNH 58519), have this feature.

Anterior alar fissure

This is a gap situated posterolateral to the orbitosphenoid between the orbitosphenoid and alisphenoid bones. It is similar in all of the genera.

Nutritive

All the dipodoids and *Cricetulus* have many nutritive foramina in the maxillary bone dorsal to the molars, in the palatine bone, and sometimes on the snout. Some maxillary nutritive foramen are very large.

Sphenofrontal

In *Cricetulus* this foramen is situated where the orbitosphenoid, alisphenoid, and squamosal bones converge in the orbit. In *Jaculus*, *Dipus*, *Paradipus*, *Pygeretmus*, *Stylodipus*, *Alactagulus*, *Cardiocranius*, and *Eozapus* there is a large fenestra in the orbit, and the orbitosphenoid is no longer united with the alisphenoid and squamosal bones, hence, no foramen is seen. The foramen, if present, may be contained within this large excavation. The other dipodoids, *Zapus*, *Napaeozapus*, *Allactaga*, *Sicista*, and *Salpingotus* lack a sphenofrontal foramen. In all of these specimens (except *Allactaga*) the alisphenoid bone is fused with the orbitosphenoid.

Foramen posterior to the sphenofrontal foramen

In *Cricetulus* this foramen is in the alisphenoid posteroventral to the sphenofrontal and anteroventral to the root of the zygoma. It is larger than the sphenofrontal foramen. A groove on the medial surface of the alisphenoid connects this opening with the sphenofrontal foramen; this groove is probably the trace of a blood vessel. None of the dipodoids have this character.

Masticatory

Two variations are seen in the dipodoids with respect to the masticatory foramen. In most specimens (except all of *Salpingotus* and one *Cricetulus*) the masticatory is confluent with the buccinator and is situated in the alisphenoid bone. Only *Salpingotus* and *Paradipus*, (AMNH 174332) have a masticatory which is not confluent with the buccinator. On the left side only in one *Cricetulus* specimen (AMNH 176254) a narrow strip of the alisphenoid bone subdivides the masticatory from the buccinator foramen, which is slightly posterolateral. Two *Napaeozapus* specimens (AMNH 180247 and AMNH 144484), on the left side, and all of the *Salpingotus* specimens have a small foramen situated anteromedially in the masticatory foramen. The foramen is continuous with a channel that transmits the masseteric nerve. The channel is seen as a groove on the medial surface of the alisphenoid.

Buccinator

In all of the dipodoids, except *Salpingotus* and *Paradipus*, the buccinator foramen is confluent with the masticatory foramen. In *Salpingotus* the extremely large buccinator foramen is situated in the alisphenoid posterolateral to the masticatory foramen. In *Paradipus* (AMNH 174332) the large buccinator foramen is posterolateral to the masticatory.

Transverse canal

There is considerable variation among the dipodoids with respect to this feature. In the majority of genera the transverse canal is situated in the basisphenoid bone dorsal to the hamular process. In *Jaculus*, *Dipus*, and *Paradipus* the bullae are inflated and consequently the transverse canal is more dorsally situated. In *Salpingotus* no transverse canal is seen, but there is a large opening into the cranium in the pterygoid region. The vessel may pass through this opening rather than through a canal.

Foramen ovale

In the dipodoids the foramen ovale is situated posterolaterally in the pterygoid region. Its anterior margin is seen as a curve in the alisphenoid bone, and its posterior margin is formed by the tympanic bulla. In *Salpingotus* it is not possible to determine solely from the skull if the foramen is in this position or if it is within a large aperture in the roof of the pterygoid fossa. In *Cricetulus* the foramen ovale is entirely within the alisphenoid bone.

Foramen ovale accessorius

This foramen is situated in the pterygoid region lateral to the foramen ovale in *Cricetulus*. The foramen is absent in all the dipodoids.

Alisphenoid canal

The alisphenoid canal is not seen in most dipodoids and all *Cricetulus*. When present in other rodents, it travels rostrally through the alisphenoid bone. In some dipodoid specimens there is a groove on the medial surface of the alisphenoid; this indicates the location of the canal, which is entirely within the cranium.

Carotid canal

There are three variations among the dipodoids with respect to this character. The carotid canal begins at the anterior end of the jugular foramen and continues anteriorly between the basioccipital and tympanic bones. In *Zapus*, *Napaeozapus*, some *Sicista*, and some *Cricetulus* a complete canal is formed by the medial surface of the bulla and the basioccipital bone. In *Salpingotus*, *Jaculus*, *Dipus*, *Stylodipus*, *Alactagulus*, *Cardiocranius*, and some *Cricetulus*, a large space is seen between the basioccipital and the bulla. In some of these specimens a groove is seen along the medial surface of the bulla and is probably the trace of the carotid canal. In *Paradipus* no space and no groove are present between the basioccipital and the medial surface of the bulla.

Eustachian canal

The eustachian canal is situated at the anteromedial portion of the bulla in *Cricetulus* and all of the dipodoids; it opens into the nasal passage. In some specimens the opening of the canal is obscured because the bulla is inflated ventrally; this apparently pushes the opening of the canal dorsally into the cranium.

Stapedial

In most of the dipodoids the stapedial foramen is within the opening of the jugular foramen. It can be seen penetrating the medial surface of the bulla dorsal and lateral to the junction of the basioccipital and the bulla. In *Cricetulus* the stapedial is anterior and ventral to the jugular foramen and thus does not share an opening with it. In *Zapus*, *Napaeozapus*, and *Sicista* the stapedial foramen is also separate from the jugular. It is anteromedial and ventral to the jugular foramen and is continuous with a groove on the medial surface of the bulla. The groove is the trace of the carotid canal. In *Cardiocranium* the stapedial foramen is again anteromedial and ventral to the jugular, but it is not continuous with the carotid canal.

Jugular

In the dipodoids the jugular foramen is situated between the basioccipital bone and the posteromedial portion of the auditory bulla. It is a lenticular shaped foramen. In some cases it shares its opening with the stapedial foramen.

Hypoglossal

All members of the Dipodoidea have a hypoglossal foramen or foramina. In *Zapus*, *Napaeozapus*, *Sicista*, *Salpingotus*, *Dipus*, *Paradipus*, some *Cricetulus*, some *Stylodipus*, some *Alactagulus*, and the one specimen of *Cardiocranium* a single foramen is present bilaterally in the basioccipital bone anterior to the condyles.

In *Cricetulus*, *Jaculus*, *Alactagulus*, some *Stylodipus*, and some *Pygeretmus* two hypoglossal foramina are present bilaterally in the basioccipital anterior to the condyles. In four specimens there is side to side variation with respect to this feature. Two *Cricetulus* (AMNH 88829 and AMNH 176254) have two hypoglossal foramina on the left side and a single one on the right. *Dipus* (AMNH 4329) and *Pygeretmus* (AMNH 176264) each have a single foramen on the left and a pair on the right.

Squamosal foramen

This tiny foramen is situated in the squamosal bone dorsal to the root of the zygoma. All *Cricetulus*, except AMNH 144217, possess this foramen. None of the dipodoid rodents have this character.

Postglenoid

The postglenoid foramen is situated ventral to the root of the zygoma and posteromedial to the glenoid fossa. All of the dipodoids have this character. However, there is considerable variation among the genera. In the zaptodids, *Zapus*, *Eozapus*, and *Napaeozapus*, the postglenoid is ventral to the root of the zygoma and is entirely contained in the squamosal bone. In addition one *Zapus* specimen (AMNH 120666) has two postglenoid foramina, the first anterior to the second. In *Cricetulus*, both the squamosal and the petiotic participate in forming the dorsal and ventral borders of the

postglenoid. In the rest of the dipodoids the postglenoid is continuous with a gap that extends from the temporal foramen to the basisphenoid. In some cases the channel begins just ventral to the root of the zygoma and continues ventromedially to the basisphenoid.

Temporal

The temporal foramen is posterodorsal to the root of the zygoma. In *Cricetulus*, *Zapus*, *Napaeozapus*, and *Eozapus* the temporal foramen is entirely within the squamosal bone. In *Salpingotus* and *Cardiocranium* the foramen is situated between the squamosal and the petrosal. In *Allactaga*, *Alactagulus*, *Pygeretmus*, *Sicista*, and *Dipus* the foramen is in the squamosal-parietal suture. In the remaining dipodoid taxa, *Stylodipus*, *Jaculus*, and *Paradipus* the temporal foramen is bordered anterodorsally by the parietal, ventrally by the squamosal, and posteriorly by the petrosal.

Posterior alar fissure

In *Dipus*, *Stylodipus*, *Jaculus*, *Pygeretmus*, *Sicista*, *Cardiocranium*, *Alactagulus*, *Paradipus*, and *Allactaga* the posterior alar fissure is continuous with both the postglenoid foramen and the foramen ovale. They are all part of a gap which extends from the dorsal surface of the bulla to the basisphenoid. In *Cricetulus*, *Zapus*, *Napaeozapus*, and *Eozapus* there is no gap. The posterior alar fissure in these specimens is continuous anteromedially with the foramen ovale, but not the with the postglenoid foramen.

Stylomastoid

The stylomastoid foramen is situated between the mastoid process and the external auditory meatus. In most of the dipodoids the stylomastoid is posterior to the external auditory meatus. In *Salpingotus* the bulla is extremely large, and the stylomastoid is ventral to the external auditory meatus.

Other cranial features

In *Paramys* and all of the dipodoids, except *Salpingotus*, the jugal bone extends dorsally along the anterior portion of the zygomatic arch to meet the lacrimal bone. The jugal and lacrimal do not meet in *Cricetulus*. In *Cricetulus*, *Zapus*, *Napaeozapus*, *Eozapus*, and *Sicista*, which have small bullae, the root of the zygoma is high relative to the bulla and is always anterodorsal to its dorsal surface. In all the remaining dipodoids, which have bullae that are enlarged both dorsally and ventrally, the root is low relative to the bulla.

A fenestra is present in the angle of the lower jaw in most dipodoids except *Sicista* and possibly *Cardiocranium* (specimen damaged). Some specimens of *Zapus* and *Napaeozapus* lack the fenestra. It is absent in *Cricetulus* and *Paramys*.

DISCUSSION

The PAUP analysis yielded two trees of 88 steps each with identical consistency indices of 0.613. The three are thus equally parsimonious. A consensus tree ([Fig 5](#)) was then generated to combine these two and to show the parts that are common to both, and the parts that cannot be resolved. The consensus tree had 93 steps and a consistency index of 0.576. The consistency index is defined as the ratio of the minimum number of steps possible divided by the number of steps observed in the phylogenetic tree. This ratio is useful for two reasons, first as a measure of homoplasy and second as an indicator of the reliability of the results. Homoplasy is any instance where similar characteristics were independently evolved. The closer the consistency index is to 1.00, the nearer the phylogeny is to the ideal possible. Consistency indices are highly correlated with the number of taxa examined (Sanderson and Donoghue, 1989); the formula for calculating an expected index is

$$CI = 0.9 - 0.022(\text{number of taxa}) + 0.000213(\text{number of taxa})^2.$$

Fifteen taxa were examined in this study, and the expected consistency index is thus 0.6179. This is very close to the actual consistency indices of this study.

The computer results support the monophyly of the Dipodoidea. The outgroup taxa, *Paramys* and *Cricetulus*, lack many of the characters present in the dipodoids. *Paramys* is considered to be primitive; *Cricetulus* has derived characters that distinguish it from *Paramys*. *Cricetulus* has lost P4, while *Paramys* retains it. In addition the posterior maxillary foramen of *Cricetulus* is completely enclosed in the pterygoid bone, while in *Paramys* the posterior maxillary foramen is lateral to the pterygoid and is wide open laterally. *Cricetulus* also has a foramen posterior to the sphenofrontal, but this is lacking in *Paramys*. The stapedial foramen in *Paramys* arises in the jugular foramen, but in *Cricetulus* it begins anteroventral to the jugular foramen. Finally, in *Paramys* the jugal bone extends to meet the lacrimal bone, but it fails to do so in *Cricetulus*.

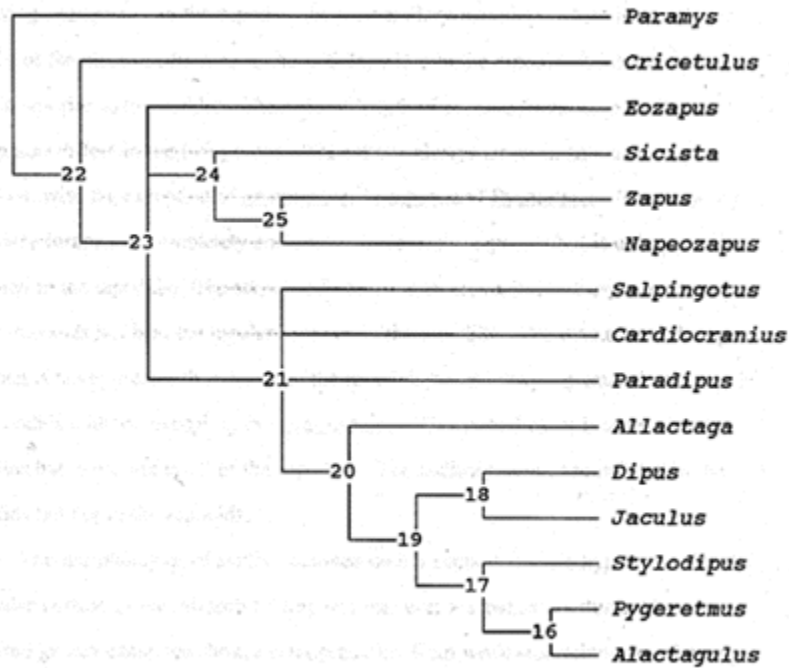

Figure 5. Consensus tree of dipodoid genera. Numbered nodes are referred to in text.

Analysis of cranial data by PAUP supported the subdivision of the superfamily Dipodoidea into two families, Zapodidae and Dipodidae. The Zapodidae include *Sicista*, *Zapus*, and *Napeozapus* and are distinguished from other dipodoids by the following characters. In the zapodids; the premaxillary-maxillary suture intersects the margin of the incisive foramina in the middle, while in the dipodids it intersects the margin anterior to the middle. The ratio of length of incisive foramen to diastemal length also differs in the two groups. The ratio is always larger in zapodids than in dipodids, with the exception of *Salpingotus*, *Eozapus*, and *Pygeretmus*. The posterior maxillary foramen is completely enclosed in bone in the zapodids but is only partially enclosed in the dipodids. The stapedial foramen is anteroventral to the jugular foramen in the zapodids but is at the jugular foramen in the dipodids. The diameter of the optic foramen is never greater than 1 mm in the zapodids but is always greater than 1 mm in the dipodids with the exception of *Cardiocranium*. The carotid canal is absent in the dipodids but is present in all of the zapodids. The auditory bullae are inflated in the dipodids but not in the zapodids.

The morphologies of skulls examined do not support Emry's hypothesis that the muscular portion of the infraorbital foramen was ever a separate aperture. The dipodoid genera examined show a clear gradation from weak separation toward nearly complete

separation of the passage for nerves and vessels. Subdivision is caused by a flange of the maxilla that arises from the anterior part of the orbital floor and from the floor of the infraorbital canal, itself. The flange leans medially, and its dorsal edge may or may not reach the wall of the rostrum. Neither part of the foramen is in the maxillary-jugal suture. Neither condition is restricted to any dipodoid group that could be considered primitive.

The placement of *Eozapus* within the consensus tree is unresolved, because it occupies different positions in the two most parsimonious trees. In one it is grouped with the Dipodidae and in the other as the sister taxon to all of the Dipodoidea. It is significant that neither cladogram places *Eozapus* within the family Zapodidae, as many classifications have done. More characters will have to be used to resolve the phylogenetic placement of this genus.

Within the subfamily Zapodidae, *Sicista* is more primitive than *Zapus* and *Napaeozapus* because it lacks some of their derived features. In *Sicista* the anterior margin of the sphenopalatine foramen is dorsal to the second molar, while in *Zapus* and *Napaeozapus* it is dorsal to the junction of the first and second molar. The further anterior this foramen is relative to the dentition, the more derived the condition. In *Paramys* the anterior margin of the sphenopalatine is dorsal to the second and third molars. In *Sicista* the diameter of the optic foramen is less than 1 mm, but in *Zapus* and *Napaeozapus* it is 1 mm. Also in *Sicista* there is a gap between the basioccipital and the medial surface of the bulla which is lacking in the other two genera. The postglenoid foramen is always separated from the posterior alar fissure in *Sicista*, but they are continuous in *Zapus* and *Napaeozapus*. In *Zapus* and *Napaeozapus* the temporal foramen is entirely within the squamosal bone, but in *Sicista* it is situated in the squamosal-parietal suture. In *Zapus* and *Napaeozapus* the margins of the sphenopalatine are either made up of the maxilla alone or of the maxillary and frontal bones. In contrast, in *Sicista* the margins of the sphenopalatine are formed by the maxillary and palatine bones.

The dipodids have several derived features in common. The posterior maxillary foramen is in the maxillary-pterygoid suture. The diameter of the optic foramen is always greater than 1.0 mm. The carotid canal has been lost. The auditory bullae are always inflated.

Within the subfamily Dipodidae, *Eozapus* is primitive to the other genera because the anterior margin of the sphenopalatine is farther posterior than it is in them. In *Eozapus* it is dorsal to the second molar, while in the other genera it is dorsal to the junction of the first and second molars. In addition *Eozapus* has a larger ratio of the incisive foramen to diastemal length than all other dipodids with the exception of *Salingotus* and *Pygeretmus*.

Allactaga, *Dipus*, *Jaculus*, *Stylodipus*, *Pygeretmus*, and *Alactagulus* all share a common ancestor at node 20 in each of the three trees and the strict consensus tree. The fact that these genera are consistently grouped together in every cladogram strongly suggests a close evolutionary relationship among them. In each of these genera the temporal foramen is situated in the squamosal-parietal suture. In the remaining dipodids *Salingotus*, *Cardiocranius*, and *Paradipus*, the temporal foramen is either between the petrosal and the squamosal bone, or it is between the parietal, squamosal, and petrosal

bones. The relationship between *Salingotus*, *Cardiocranius*, and *paradipus* is not clear from the consensus tree, because these three taxa occupy different positions in the three most parsimonious trees generated. They each have distinct characteristics. More characters are needed in order to evaluate the evolutionary relationships between these genera.

Dipus and *Jaculus* are closely related and share a common ancestor at node 18. In the orbital region there are morphological differences that distinguish these genera from the others. The diameter of the optic foramen is unique because it is greater than 2 mm; all of the other dipodids have smaller diameters than this. In addition the posterior margin of the orbitosphenoid in *Jaculus* and *Dipus* is not fused or in contact with the alisphenoid. In all the other dipodids and zapodids these two bones are touching. *Stylodipus*, *Alactagulus*, and *Pygeretmus* lack the thus differ from *Jaculus*, *Dipus*, and *Alactagulus*. *Pygeretmus* closely related and share common ancestry. They have both lost the premolar, while *Stylodipus* retains this primitive character.

A "bootstrap" analysis was performed on the consensus tree, and a majority rule consensus tree ([Fig. 6](#)) was generated. In 98 % of the resampling, *Paramys* and *Cricetulus* grouped together as primitive taxa, and the dipodoidea were a monophyletic group. The division of the Dipodoidea into two families, Zapodidae and Dipodidae, was not strongly supported because they formed separate monophyletic groups in only 33 % of the analyses. There are a number of explanations for this low percentage for a division that is widely recognized among mammalogists. A high ratio of characters to taxa is required in order to avoid bias in "bootstrap" analysis; the ratio in this study was relatively low, less than 3:1. In addition, characters that provide no phylogenetic information and those do not fit the same groupings lower the frequency of a particular combination of taxa. The group of taxa that constitute the family Dipodidae were united in 65 % of the tests, and this assemblage is strongly supported. Within the Dipodidae *Dipus* and *Jaculus* grouped together 49 % of the time; within the Zapodidae *Zapus* and *Napaeozapus* were joined 59 % of the time. That these pairs of genera are each other's closest relative is supported.

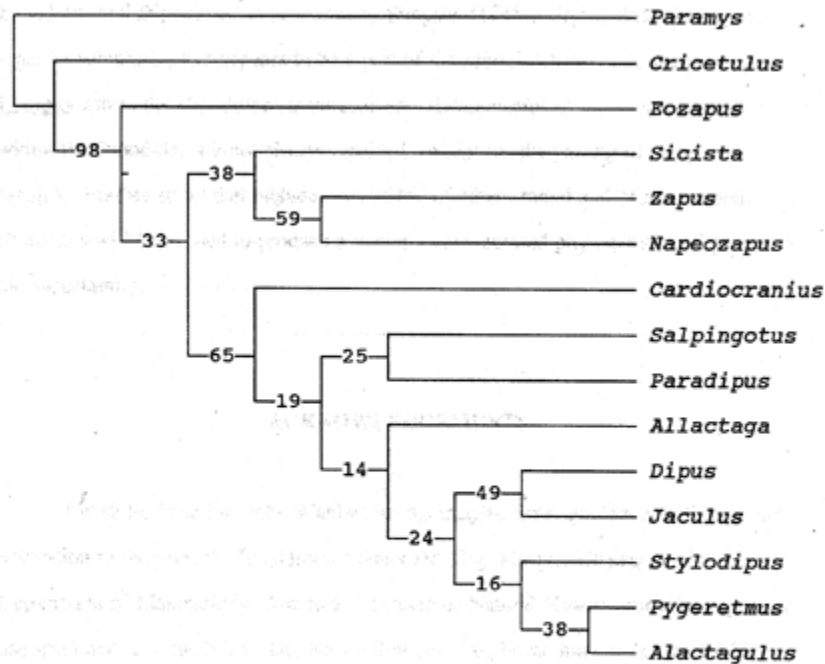

Figure 6. Majority rule consensus tree of dipodoid genera. Numbers are percent of times that resampling yielded a given phylogenetic association of taxa.

CONCLUSIONS

The data support subdivision of the superfamily Dipodoidea into two families, Zapodidae and Dipodidae, as proposed by Simpson (1945). *Sicista* does not require a separate subfamily, and appears to be a part of the zapodid clade. The status of *Eozapus* within the Dipodoidea is unresolved. Relationships of the various genera within the Dipodidae are not clearly resolved, except for the pairing of *Dipus* and *Jaculus*. Further study that includes evaluation of other cranial and of non-cranial characters will be needed to produce a strongly corroborated phylogeny of all genera in the superfamily.

ACKNOWLEDGEMENTS

I wish to thank Dr. John Wahlert for his insight, time, guidance, patience, and dedication to the project. In addition I thank Dr. Guy Musser, Chairman of the Department of Mammalogy, American Museum of Natural History, for allowing me to use specimens and facilities. Dr. Nancy Simmons taught me how to use the PAUP program and the "bootstrapping" technique of resampling data. Miss Marie Lawrence kindly shared her office for the duration of this research. Mr. Chester Tarka and Ms. Lorraine Meeker made slides for my oral presentation and provided good conversation.

LITERATURE CITED

Bugge, J.

1974. The cephalic arterial system in insectivores, primates, rodents and lagomorphs with special reference to the systematic classification. **Acta. Anat** **87 (suppl. 62)**: 98-127.

Ellerman, J. R.

1940. The families and genera of living rodents. Vol. 1. Rodents other than Muridae. London: **British Mus. Nat. Hist.**, 689 pp.

Emry, R. J.

1981. New material of the Oligocene muroid rodent *Nonomys*, and its bearing on muroid origins. **Amer. Mus. Novitates** 2712: 1-14.

Honacki, J. H., K. E. Kinman, and J. W. Koepl (eds.)

1982. **Mammal species of the world**. Lawrence: Assoc. Syst. Coll., 694 pp.

Jones, Brenda

1988. **Style manual: Scientific serial publications**. New York: Amer. Mus. Nat. Hist., 50 pp.

Klingener, D.

1984. Gliroid and dipodoid rodents. In S. Anderson and J. K. Jones, Jr., (eds.), **Orders and families of Recent mammals of the world**, pp. 381-388. New York: John Wiley and Sons.

Miller, M. E.

1964. **Anatomy of the dog**. Philadelphia: W. B. Saunders Co., 941 pp.

Romer, A. S.

1966. **Vertebrate paleontology**,. Chicago: Univ. Chicago Pr., 468 pp.

Sanderson, M. J., and M. J. Donoghue

1989. Patterns of variation in levels of homoplasy. **Evolution** 43: 1781-1795.

Sheets, B. S.

1989. **Cranial anatomy of *Jaculus orientalis* (Rodentia, Dipodoidea): New evidence for close relationship of dipodoid and muroid rodents**. Unpublished Honors Thesis, Baruch College, 37 pp.

Simpson, G. G.

1945. The principles of classification and a classification of mammals. **Bull. Amer. Mus. Nat. Hist.** 85: 1-350.

Stein, B. R.

1990. Limb myology and phylogenetic relationships in the superfamily Dipodoidea (birch mice, jumping mice, and jerboas). **Z. zool. Syst. Evolut.-forsch.** 28: 299-314.

Swofford, D. L.

1989. **Phylogenetic analysis using parsimony**. [Computer program distributed on floppy disk]. Illinois Nat. Hist Surv.

Tullberg, T.

1899. Ueber das System der Nagethiere. Eine Phylogenetische Studie. **Nova Acta Regiae Soc. Scient Upsala**, ser. 3, vol. 18: v + 514 pp., 57 pls.

Wahlert, J. H.

1974. The cranial foramina of protrogomorphous rodents; an anatomical and phylogenetic study. **Bull. Mus. Comp. Zool.** 146: 363-410.

1991. The Harrymyinae, a new heteromyid subfamily (Rodentia, Geomorpha), based on cranial and dental morphology of Harrymys Munthe, 1988. **Amer. Mus. Novitates** 3013: 1-23.

Wood, A. E.

1974. Rodentia. In **Encyclopedia Britannica**, Inc., vol 15: 969-980.

Appendices

APPENDIX A

APPENDIX A
Sample Data Capture Page
 Character State Polarization

5 Infraorbital Foramen

State 0 is primitive as in Paramys; magnitude of number indicates degree of derivation or specialization from the primitive character state.

0	28214	S	ⓐ	Divided completely into 2 foramina, but border visible
1	5893	S	ⓑ	
2	17625	S	ⓒ	
3	17632	S	ⓓ	
4	5851	S	ⓔ	ⓐ Incompletely divided, nearly sutured.
5	5841	S	ⓕ	ⓑ Only a small channel indicates where the smaller infraorbital is located.
6	8413	S	ⓖ	ⓒ Not divided completely.
7	5863	S	ⓗ	
8	5868	S	ⓓ	
9	5864	S	ⓓ	
10	17653	P	ⓓ	
11	504	P	ⓓ	
12	704	P	ⓓ	
13	206505	Sc	ⓓ	ⓓ There is only a single foramen with no evidence of a smaller subdivision.
14	206587	Sc	ⓓ	
15	206586	Sc	ⓓ	
16	17084	Sc	ⓓ	
17	206522	Sc	ⓓ	
18	37837	Sc	ⓓ	
19	10580	Sc	ⓓ	
20	8244	C	ⓓ	
21	8454	C	ⓓ	
22	24431	Sul	ⓓ	
23	32	Sul	ⓓ	
24	35	Sul	ⓓ	
25	7442	Sul	ⓓ	
26	24430	Sul	ⓓ	
27	24429	Sul	ⓓ	
28	5733	Cr	ⓓ	176254 Cr ⓓ
29	5714	Cr	ⓓ	32074 Cr ⓓ
30	5798	Cr	ⓓ	26724 Cr ⓓ
31	5632	Cr	ⓓ	176484 Cr ⓓ
32	5700	Cr	ⓓ	
33	68829	Cr	ⓓ	

APPENDIX B Character State Polarization

State 0 is primitive as in Paramys; magnitude of number indicates degree of derivation or specialization from the primitive character state.

1. Premaxillary-maxillary suture intersects incisive foramina
 - 0 near back
 - 1 near middle
 - 2 anterior to middle

2. ratio of incisive foramen length to diastemal length
 - 0 40 < > 50
 - 1 50 < > 60

- 2 60<>70
- 3 70 <> 80
- 4 80<>90

3. Premolars

- 0 with P4
- 1 lacking P4

4. Posterior palatine foramen

- 0 within palatine bone
- 1 in palatine-maxillary suture

5. Posterior border of posterior palatine foramen medial to

- 0 posterior part of M1
- 1 medial part of M2
- 2 posterior part of M2
- 3 posterior part of M3

6. Posterior maxillary foramen

- 0 wide open laterally
- 1 partially enclosed
- 2 completely enclosed
- 3 closed

7. Posterior maxillary foramen

- 0 lateral to pterygoid bone
- 1 in maxillary-ptyergoid suture
- 2 within pterygoid bone

8. Infraorbital foramen

- 0 single hole
- 1 subdivided, stage 1
- 2 subdivided, stage 2
- 3 subdivided, stage 3

9. Zygomatic foramen

- 0 lacking
- 1 present

10. Nasolacrimal foramen

- 0 within orbit
- 1 medial to infraorbital canal

11. Sphenopalatine margin

- 0 maxilla, frontal, palatine
- 1 maxilla, frontal

2 maxilla, palatine, nonossification
3 maxilla entirely

12. Anterior margin of sphenopalatine foramen dorsal to
0 M1 M2 junction
1 M2

13. Orbital nonossification
0 lacking
1 present

14. Ethmoid foramen
0 surrounded by bone
1 united with orbital nonossification

15. Ethmoid foramen
0 in orbitosphenoid-frontal suture
1 in frontal bone

16. Ethmoid foramen dorsal to
0 posterior part of M3
1 M2

17. Optic foramen diameter
0 1.0 mm
1 <1.0 mm
2 > 1.0 mm
3 >2.0 mm

18. Middle of optic foramen dorsal to
0 posterior to M3
1 M3
2 junction of M2 and M3

19. Posterior orbitosphenoid and anterior alisphenoid
0 sutural contact
1 fused, no suture
2 separated

20. Interorbital foramen
0 absent
1 present anteroventral or ventral to optic foramen

21. Dorsal palatine foramen
0 surrounded by bone
1 joined with nonossification

22. Middle of dorsal palatine foramen dorsal to
0 M2 M3 junction
1 M2
23. Sphenofrontal foramen
0 present
1 absent or combined with nonossification
24. Foramen posterior to sphenofrontal
0 absent
1 present
25. Masticatory and buccinator foramina
0 separated
1 confluent
26. Foramen present medial to masticatory foramen
0 absent
1 present
27. Transverse canal in basioccipital
0 present
1 lacking
28. Foramen ovale
0 within alisphenoid bone
1 between alisphenoid bone and auditory bulla
29. Foramen ovale accessorius
0 present
1 absent
30. Alisphenoid canal
0 contained within alisphenoid bone
1 within cranium
31. Carotid canal
0 carotid canal present
1 carotid canal absent
32. Gap between bulla and basioccipital
0 absent
1 present

33. Stapedial foramen or artery

0 present

1 absent

34. Stapedial foramen

0 at jugular foramen

1 anteroventral to jugular foramen

35. Squamosal foramen

0 absent

1 present

36. Postglenoid foramen

0 completely surrounded by bone

1 between squamosal and petrosal and separate from anterior alar fissure

2 between squamosal and petrosal and combined with anterior alar fissure

37. Temporal foramen

0 in squamosal-parietal suture

1 met by squamosal, parietal, and petrosal

2 within squamosal

3 between squamosal and petrosal

38. Stylomastoid foramen

0 posterior to external auditory meatus

1 ventral to external auditory meatus

39. Lacrimal and jugal bones

0 meet

1 do not meet

40. Fenestra in angle of lower jaw

0 absent

1 present

41. Auditory bullae

0 very small

1 normal size

2 enlarged

APPENDIX C Data Matrix

Data matrix of character states in dipodoid and outgroup taxa *Paramys* and *Cricetulus*) used for PAUP analysis. Boxes containing multiple character states separated by / indicate that multiple states occur in specimens that constituted the sample of the genus.

	1	2	3	4	5	6	7	8	9	
	Incisive	Ratio incisiv	Premolars	Palatine	Border palat	Post max fo	Post max fc	Infraorb for	Zygo for	
1	Zapus	1	4	0	1	2	2	1	2	0
2	Napeozapus	1	3	1	1	2	2	1	3	0
3	Sicista	1	4	0	1	2	1/2	1	1	0
4	Pygeretmus	0/2	3	1	1	2	1/2	1	3	1
5	Allactaga	0/1/2	2	0	1	2	1	1	1/2	1
6	Alactagulus	2	2	1	1	1/2	1/2	1	1/3	1
7	Stylodipus	0/2	2	0	1	2	1/2	1	3	1
8	Dipus	0/2	2	0	1	2	1/2	1	3	1
9	Jaculus	2	1	1	1	2	1	1	3	1
10	Salpingotus	1	4	0	1	2	2	2	1	1
11	Cardiocranius	0	2	0	1	2	1	1	1	1
12	Eozapus	0/2	3	0	1	2	1/2	1	1	0
13	Paradipus	0	2	1	1	2	1/2	1	1/3	1
14	Cricetulus	0/2	2	1	0/1	2	3	2	0	0
15	Paramys	0	0	0	0	0	0	0	0	0

	10	11	12	13	14	15	16	17	18	
	Nasola for	Sphenopal	Ant sphenop	Orbital non	Ethmoid for	Ethmoid for	Dorsal ethm	Optic for	Dorsal optic	
1	Zapus	1	1/3	2	1	1	1	1	0	0
2	Napeozapus	1	1	2	1	1	1	1	0	0
3	Sicista	1	2	1	1	1	1	1	0	0
4	Pygeretmus	1	2	2	1	1	1	1	2	0
5	Allactaga	1	2	2	1	1	1	1	2	0
6	Alactagulus	1	2	2	1	1	1	1	2	0
7	Stylodipus	1	2	2	1	1	1	1	2	0
8	Dipus	1	2	1	1	1	1	1	3	0
9	Jaculus	1	2	2	1	1	1	1	3	0
10	Salpingotus	1	2	3	1	1	1	1	2	0
11	Cardiocranius	1	2	2	0	0	1	1	1	0
12	Eozapus	1	2	1	0	0	1	1	2	0
13	Paradipus	1	2	2	1	1	1	1	2	0
14	Cricetulus	1	0	2	0	0	1	1	0	0
15	Paramys	0	0	0	0	0	0/1	0	0	0

		19	20	21	22	23	24	25	26	27
		Postorbital r	Interorbita	Dorsopal	Dorsopal2	Sphenofront	Postsphefr	Mast & bucc	Medial mast	Trans canal
1	Zapus	1	0/1	1	1	1	0	1	0	0
2	Napeozapus	1	0/1	1	1	1	0	1	0/1	0
3	Sicista	1	0	1	1	1	0	1	0	0
4	Pygeretmus	1	0	1	1	1	0	1	0	0
5	Allactaga	1	1	1	1	1	0	1	0	0
6	Alactagulus	1	0	1	1	1	0	1	0	0
7	Stylodipus	1	0	1	1	1	0	1	0	0
8	Dipus	2	1	0/1	1	1	0	1	0	0
9	Jaculus	2	0/1	0/1	1	1	0	1	0	0
10	Salpingotus	1	1	1	1	1	0	0	1	1
11	Cardiocranius	1	1	1	0	1	0	1	0	0
12	Eozapus	1	0	1	1	1	0	1	0	0
13	Paradipus	1	1	0	1	1	0	0	0	0
14	Cricetulus	1	0	0	0	0	1	0/1	0	0
15	Paramys	0	0	0	0	0	0	0	0	0

		28	29	30	31	32	33	34	35	36
		For oval	For oval 2	Allisphen	Car canal	Gap	Stapedial	Stap2	Squamosal	Postglenoid
1	Zapus	1	1	1	0	0	1	1	0	0/1
2	Napeozapus	1	1	1	0	0	1	1	0	0/1
3	Sicista	1	1	1	0	1	1	1	0	2
4	Pygeretmus	1	1	1	1	1	1	0	0	2
5	Allactaga	1	1	1	1	0/1	1	0	0	2
6	Alactagulus	1	1	1	1	1	1	0	0	2
7	Stylodipus	1	1	1	1	1	1	0	0	2
8	Dipus	1	1	1	1	1	1	0	0	2
9	Jaculus	1	1	1	1	1	1	0	0	2
10	Salpingotus	1	1	1	1	1	1	0	0	2
11	Cardiocranius	1	1	1	1	1	1	1	0	2
12	Eozapus	1	1	1	1	0	1	0	0	0/1
13	Paradipus	1	1	1	0	0	1	0	0	2
14	Cricetulus	0	0	1	0	0/1	1	1	0/1	1
15	Paramys	0	0	0	?	0	0	0	0	0

		37	38	39	40	41
		Temporal	Stylomast	La jugal	Lower Jaw	Bulla
1	Zapus	2	0	0	0/1	1
2	Napeozapus	2	0	0	0/1	1
3	Sicista	0	0	0	0	1
4	Pygeretmus	0	0	0	1	2
5	Allactaga	0	0	0	1	2
6	Alactagulus	0	0	0	1	2
7	Stylodipus	1	0	0	1	2
8	Dipus	0	0	0	1	2
9	Jaculus	1	0	0	1	2
10	Salpingotus	3	1	1	1	2
11	Cardiocranius	3	0	?	1	2
12	Eozapus	2	0	0	?	1
13	Paradipus	1	0	0	1	2
14	Cricetulus	2	0	1	0	1
15	Paramys	0	0	0	0	0

© Copyright to this work is retained by the author[s]. Permission is granted for the noncommercial reproduction of the complete work for educational or research purposes.
